



## Pressure Injectable Multiple-Lumen Central Venous Catheterization Product

### Safety and Efficacy Considerations:

Do not use if package has been previously opened or damaged.

**Warning:** Prior to use read all package insert warnings, precautions, and instructions. Failure to do so may result in severe patient injury or death.

The product is designed for single use only. Do not resterilize or reuse. Do not alter the catheter, spring-wire guide, or any other kit/set component during insertion, use, or removal.

Procedure must be performed by trained personnel well versed in anatomical landmarks, safe technique, and potential complications.

**Warning:** Do not place the catheter into or allow it to remain in the right atrium or right ventricle (refer to Fig. 1).



Fig. 1

**Cardiac Tamponade:** It has been documented by many authors that placement of indwelling catheters in the right atrium is a dangerous practice<sup>5,6,7,10,13,25,31</sup> that may lead to cardiac perforation and tamponade.<sup>5,6,7,10,25,31</sup> Although cardiac tamponade secondary to pericardial effusion is uncommon, there is a high mortality rate associated with it.<sup>33</sup> Practitioners placing central venous catheters must be aware of this potentially fatal complication before advancing the catheter too far relative to patient size.

No particular route or catheter type is exempt from this potentially fatal complication.<sup>31</sup> The actual position of the tip of the indwelling catheter should be confirmed by visual imaging after insertion.<sup>5,6,12,25,31,36</sup> Central venous catheters should be placed in the superior vena cava<sup>5,6,7,12,24,38</sup> above its junction with the right atrium and parallel to the vessel wall<sup>17,38</sup> and its distal tip positioned at a level above either the azygos vein or the carina of the trachea, whichever is better visualized.

Central venous catheters should not be placed in the right atrium unless specifically required for special relatively short term procedures such as aspiration of air emboli during neurosurgery. Such procedures are, nevertheless, risk prone and should be closely monitored and controlled.

### New Important Product Information:

Arrow® Multiple-Lumen Central Venous Catheterization Products are now Pressure Injectable. All specified manufacturer instructions for use, contraindications, warnings, and precautions must be followed.

### Warnings and Precautions related to Pressure Injection:

1. **Warning:** Assess each patient for appropriateness of a pressure injection procedure. Pressure injection procedures must be performed by trained personnel well versed in safe technique and potential complications.
2. **Warning:** Obtain a visual image to confirm catheter tip position prior to each pressure injection.
3. **Warning:** Ensure patency of each lumen of catheter prior to pressure injection to minimize the risk of catheter failure and/or patient complications.
4. **Warning:** Discontinue pressure injections at first sign of extravasation or catheter deformation. Follow hospital protocol for appropriate medical intervention.
5. **Precaution:** To minimize the risk of catheter failure and/or tip displacement, do not exceed ten (10) injections or catheter's maximum recommended flow rate located on product labeling and catheter luer hub.
6. **Precaution:** Warm contrast media to body temperature prior to pressure injection to minimize the risk of catheter failure.
7. **Precaution:** Pressure limit settings on injector equipment may not prevent over pressurizing an occluded or partially occluded catheter.

8. **Precaution:** Use appropriate administration set tubing between catheter and pressure injector equipment to minimize the risk of catheter failure.
9. **Precaution:** Follow the contrast media manufacturer's specified instructions for use, contraindications, warnings, and precautions.

## A Suggested Procedure for Pressure Injection: Use sterile technique.

1. **Warning:** Obtain a visual image to confirm catheter tip position prior to each pressure injection.
2. Remove injection cap from appropriate extension line of catheter.
3. Check for catheter patency:
  - Attach 10 mL syringe filled with sterile normal saline.
  - Aspirate catheter for adequate blood return.
  - Vigorously flush catheter. **Warning:** Ensure patency of each lumen of catheter prior to pressure injection to minimize the risk of catheter failure and/or patient complications.
4. Detach syringe.
5. Attach pressure injection administration set tubing to appropriate extension line of catheter according to manufacturer's recommendations. **Precaution:** To minimize the risk of catheter failure and/or tip displacement, do not exceed ten (10) injections or catheter's maximum recommended flow rate located on product labeling and catheter luer hub.
6. Inject contrast media in accordance with hospital protocol. **Precaution:** Warm contrast media to body temperature prior to pressure injection to minimize the risk of catheter failure.
7. Disconnect catheter from pressure injector equipment.
8. Flush catheter using 10 mL syringe or larger filled with sterile normal saline.
9. Disconnect syringe and replace with sterile injection cap on catheter extension line.

**NOTE: Do not exceed ten (10) pressure injections.**

## Indications for Use:

The Arrow® Multiple-Lumen Catheter is indicated to provide short-term (< 30 days) central venous access for the treatment of diseases or conditions requiring central venous access including, but not limited to:

1. multiple infusions of fluids, medications, or chemotherapy
2. infusion of fluids that are hypertonic, hyperosmolar, or have divergent pH values
3. frequent blood sampling or blood/ blood component infusions
4. infusion of incompatible medications
5. Total Parenteral Nutrition (TPN)
6. central venous pressure monitoring
7. lack of usable peripheral IV sites
8. replacement of multiple peripheral sites for IV access
9. injection of contrast media

When used for pressure injection of contrast media, do not exceed maximum indicated flow rate for each catheter lumen. The maximum pressure of power injector equipment used with the pressure injectable CVC may not exceed 400 psi.

## Contraindications:

None known.

## Warnings and Precautions:\*

1. **Warning:** Do not place catheter into or allow it to remain in right atrium or right ventricle. Central vein catheters should be positioned so that distal tip of the catheter is in the superior vena cava (SVC) above the junction of the SVC and the right atrium and lies parallel to the vessel wall. For femoral vein approach, the catheter should be advanced into the vessel so that the catheter tip lies parallel to the vessel wall and does not enter the right atrium.
2. **Warning:** Practitioners must be aware of complications associated with central vein catheters including cardiac tamponade secondary to vessel wall, atrial or ventricular perforation, pleural and mediastinal injuries, air embolism, catheter embolism, catheter occlusion, thoracic duct laceration, bacteremia, septicemia, thrombosis, inadvertent arterial puncture, nerve damage, hematoma, hemorrhage, and dysrhythmias.
3. **Warning:** For high pressure injection applications, only utilize catheters indicated for such applications. Catheters not indicated for high pressure applications can result in inter-lumen crossover or rupture with potential for injury.
4. **Warning:** Do not cut catheter to alter length.
5. **Warning:** To minimize the risk of possible air embolism, do not leave UserGard® hub connected to injection site.
6. **Warning:** Practitioners must be aware of the potential for entrapment of spring-wire guide by any implanted device in the circulatory system (i.e., vena cava filters, stents). Review patient's history before catheterization procedure to assess for possible implants. Care should be taken regarding the length of spring-wire guide inserted. It is recommended that if patient has a circulatory system implant, catheter procedure be done under direct visualization to minimize the risk of spring-wire guide entrapment.<sup>2</sup>
7. **Warning:** Do not cut spring-wire guide to alter length. Do not withdraw spring-wire guide against needle bevel to minimize the risk of possible severing or damaging of spring-wire guide.
8. **Warning:** Do not use excessive force when introducing the spring-wire guide or tissue dilator as this can lead to vessel perforation and bleeding.
9. **Warning:** Passage of the spring-wire guide into the right heart can cause dysrhythmias, right bundle branch block,<sup>13</sup> and a perforation of the vessel wall, atrial or ventricular.
10. **Warning:** Aspiration with spring-wire guide in place will cause introduction of air into Arrow® Raulerson Syringe.
11. **Warning:** Do not leave tissue dilator in place as an indwelling catheter to minimize the risk of possible vessel wall perforation.
12. **Warning:** Although the incidence of spring-wire guide failure is extremely low, practitioner should be aware of the potential for breakage if undue force is applied to the spring-wire guide.

13. **Warning:** Do not apply excessive force in removing spring-wire guide or catheter. If withdrawal cannot be easily accomplished, a visual image should be obtained and further consultation requested.
  14. **Warning:** The practitioner must be aware of potential air embolism associated with leaving open needles or catheters in central venous puncture sites or as a consequence of inadvertent disconnects. To lessen the risk of disconnects, only securely tightened Luer-Lock connections should be used with this device. Follow hospital protocol to guard against air embolism for all catheter maintenance.
  15. **Warning:** Since the residual catheter track remains an air entry point until completely sealed, the occlusive dressing should remain in place for at least 24-72 hours dependent upon the amount of time the catheter was indwelling.<sup>20,31</sup>
  16. **Warning:** Care must be taken to minimize the risk of sharps injury. Clinicians must adhere to US OSHA or other governmental standards for blood borne pathogens. Due to the risk of exposure to HIV (Human Immunodeficiency Virus) or other blood borne pathogens, health care workers should routinely use universal blood and body-fluid precautions in the care of all patients.
  17. **Precaution:** Alcohol and acetone can weaken the structure of polyurethane materials. Check ingredients of prep sprays and swabs for acetone and alcohol content. Acetone: Do not use acetone on catheter surface. Alcohol: Do not use alcohol to soak catheter surface or to restore catheter patency. Care should be taken when instilling drugs containing high concentration of alcohol. Always allow alcohol to dry completely prior to applying dressing.
  18. **Precaution:** Some disinfectants used at the catheter insertion site contain solvents, which can attack the catheter material. Assure insertion site is dry before dressing.
  19. **Precaution:** Place patient in slight Trendelenburg position as tolerated to reduce the risk of air embolism. If femoral approach is used, place patient in supine position.
  20. **Precaution:** Do not attempt to remove needles that have been placed into Sharps Away II™ Locking Disposal Cup. These needles are secured in place. Damage may occur to needles if they are forced out of disposal cup.
  21. **Precaution:** Do not re-use needles after they have been placed into the foam SharpsAway® system. Particulate matter may adhere to needle tip.
  22. **Precaution:** The color of the blood aspirated into the Arrow® Raulerson Syringe is not always a reliable indicator of venous access.<sup>24</sup> Do not reinsert needle into introducer catheter.
  23. **Precaution:** To minimize the risk of leakage of blood from Arrow® Raulerson Syringe cap, do not reinfuse blood with spring-wire guide in place.
  24. **Precaution:** Maintain firm grip on spring-wire guide at all times.
  25. **Precaution:** Once cutaneous puncture site is enlarged, retract scalpel in the protected position to minimize the risk of cutting the spring-wire guide.
  26. **Precaution:** If provided, catheter clamp and fastener must not be attached to catheter until spring-wire guide is removed.
  27. **Precaution:** To minimize the risk of damage to extension lines from excessive pressure, each clamp must be opened prior to infusing through that lumen.
  28. **Precaution:** Visual exam must show the catheter located in the right side of the mediastinum in the SVC with the distal end of catheter parallel to the vena cava wall and its distal tip positioned at a level above either the azygos vein or the carina of the trachea, whichever is better visualized.
  29. **Precaution:** Only visual imaging examination of catheter placement can ensure the catheter tip has not entered the heart or no longer lies parallel to the vessel wall. If catheter position has changed, immediately obtain a visual image to confirm catheter tip position.
  30. **Precaution:** Do not staple/suture directly to outside diameter of catheter to minimize the risk of cutting or damaging the catheter or impeding catheter flow.
  31. **Precaution:** Do not place staple over catheter body or extension lines except at indicated anchoring location to minimize the risk of damage to the catheter.
  32. **Precaution:** Maintain the insertion site with regular meticulous redressing using aseptic technique.
  33. **Precaution:** Indwelling catheters should be routinely inspected for desired flow rate, security of dressing, correct catheter position, and for secure Luer-Lock connection. Use centimeter markings to identify if the catheter position has changed.
  34. **Precaution:** Use of a syringe smaller than 10 mL to irrigate or de clot an occluded catheter may cause intraluminal leakage or catheter rupture.<sup>32</sup>
  35. **Precaution:** Heparin-induced thrombocytopenia (HIT) has been reported with the use of heparin flush solutions.
  36. **Precaution:** For blood sampling, temporarily shut off remaining port(s) through which solutions are being infused.
  37. **Precaution:** Prior to attempting a catheter exchange procedure, remove catheter clamp and fastener (where provided).
  38. **Precaution:** To minimize the risk of cutting catheter, do not use scissors to remove dressing.
  39. **Precaution:** To minimize the risk of catheter breakage, do not exert excessive force while removing the catheter.
  40. **Precaution:** Properly dispose of sharps in sharps container in accordance with US OSHA or other governmental standards for blood borne pathogens and/or institutional policy.
- A Suggested Procedure:**  
**Use sterile technique.**
1. **Precaution:** Place patient in slight Trendelenburg position as tolerated to reduce the risk of air embolism. If femoral approach is used, place patient in supine position.
  2. Prep and drape puncture site as required.
  3. Perform skin wheal with desired needle (25 Ga. or 22 Ga. needle).
  4. In kits where provided, the SharpsAway II™ Locking Disposal Cup is used for disposal of needles (15 Ga. - 30 Ga.).
    - Using one-handed technique, firmly push needles into disposal cup holes (refer to Fig. 2).

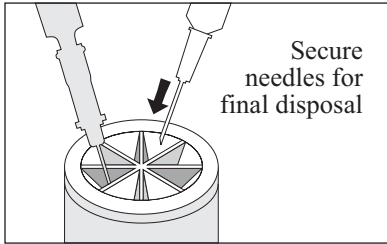

Fig. 2

- Once placed into disposal cup, needles will be automatically secured in place so that they cannot be reused.
- Discard entire cup, at completion of procedure, into an approved sharps container.

**Precaution: Do not attempt to remove needles that have been placed into SharpsAway II™ Locking Disposal Cup. These needles are secured in place. Damage may occur to needles if they are forced out of disposal cup.**

Where provided, a foam SharpsAway® system may be utilized by pushing needles into foam after use. **Precaution: Do not re-use needles after they have been placed into the foam SharpsAway® system. Particulate matter may adhere to needle tip.**

5. Prepare catheter for insertion by flushing each lumen with normal saline, to establish patency, and prime the lumens. Attach injection caps to appropriate extension lines. Leave distal extension line uncapped for spring-wire guide passage. **Warning: Do not cut catheter to alter length.**

**Arrow UserGard® Needle-Free Injection Hub (where provided) Instructions for Use:**

- Attach Luer end of UserGard® hub to syringe.
- Prepare injection site with alcohol or appropriate antiseptic per standard hospital protocol.
- Remove red dust cap from the UserGard®.
- Press UserGard® hub onto injection site and twist to lock on pin (refer to Fig. 3).

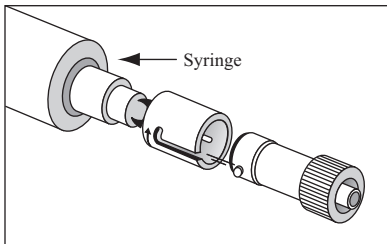

Fig. 3

- Inject or withdraw fluid as required.
- Disengage UserGard® hub from injection site and discard. **Warning: To minimize the risk of possible air embolism, do not leave UserGard® hub connected to injection site.** Single use only.

6. Locate vein using ultrasound imaging, if available. Insert introducer needle with attached Arrow® Raulerson Syringe, where provided, into vein and aspirate. (If larger introducer needle is used, vessel may be pre-located with 22 Ga. locator needle and syringe.) Remove locator needle.

**Alternate Technique:**

Catheter/needle may be used in the standard manner as alternative to introducer needle. If catheter/needle is used, Arrow® Raulerson Syringe will function as a standard syringe, but will not pass spring-wire guide. If no free flow of venous blood is observed after needle is removed, attach syringe to the catheter and aspirate until good venous blood flow is established. **Precaution: The color of the blood aspirated into Arrow® Raulerson Syringe is not always a reliable indicator of venous access.<sup>17</sup> Do not reinsert needle into introducer catheter.**

7. Because of the potential for inadvertent arterial placement, one of the following techniques should be utilized to verify venous access. Insert the fluid primed blunt tip transduction probe into the rear of the plunger and through the valves of the Arrow® Raulerson Syringe. Observe for central venous placement via a wave form obtained by a calibrated pressure transducer. Remove transduction probe (refer to Fig.4).

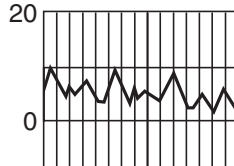

Fig. 4

**Alternate Technique:**

If hemodynamic monitoring equipment is not available to permit transducing a central venous wave form, check for pulsatile flow by either using the transduction probe to open the syringe valving system or by disconnecting the syringe from the needle. Pulsatile flow is usually an indicator of inadvertent arterial puncture.

8. Using the two-piece Arrow Advancer™, advance spring-wire guide through syringe into vein. **Warning: Aspiration with spring-wire guide in place will cause introduction of air into Arrow® Raulerson Syringe. Precaution: To minimize the risk of leakage of blood from Arrow® Raulerson Syringe cap, do not reinfuse blood with spring-wire guide in place.**

**Two-Piece Arrow Advancer™ Instructions for Use:**

- Using your thumb, straighten the “J” by retracting spring-wire guide into the Arrow Advancer™ (refer to Figs. 5, 6).

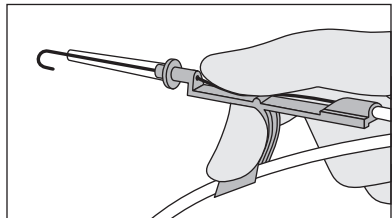

Fig. 5

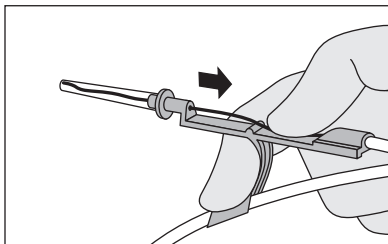

Fig. 6

When tip is straightened, spring-wire guide is ready for insertion. Centimeter marks on spring-wire guide are referenced from “J” end. One band indicates 10 cm, two bands 20 cm, and three bands 30 cm.

**Introducing the Spring-Wire Guide:**

- Place tip of Arrow Advancer™ – with “J” retracted – into the hole in rear of Arrow® Raulerson Syringe plunger (refer to Fig. 7).

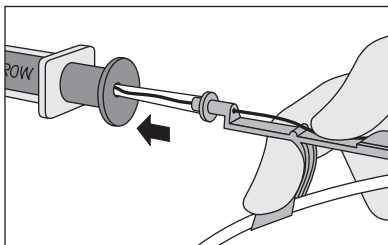

Fig. 7

- Advance spring-wire guide into Arrow® Raulerson Syringe approximately 10 cm until it passes through syringe valves (refer to Fig. 8).

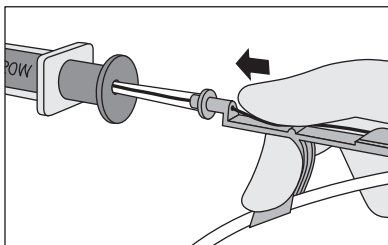

Fig. 8

- Raise your thumb and pull Arrow Advancer™ approximately 4 - 8 cm away from Arrow® Raulerson Syringe. Lower thumb onto Arrow Advancer™ and while maintaining a firm grip on spring-wire guide, push assembly into syringe barrel to further advance spring-wire guide. Continue until spring-wire guide reaches desired depth (refer to Fig. 9).

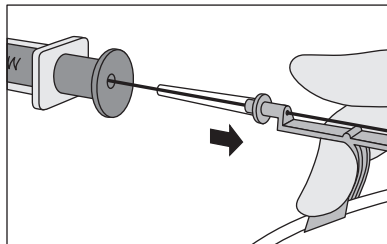

Fig. 9

**Alternate Technique:**

If a simple straightening tube is preferred, the straightening tube portion of the Arrow Advancer™ can be disconnected from the unit and used separately.

Separate the Arrow Advancer™ tip or straightening tube from blue Arrow Advancer™ unit. If “J” tip portion of spring-wire guide is used, prepare for insertion by sliding the plastic tube over “J” to straighten. The spring-wire guide should then be advanced in routine fashion to desired depth.

- Advance spring-wire guide until triple band mark reaches rear of Arrow® Raulerson Syringe plunger. Advancement of “J” tip may require a gentle rotating motion. **Warning: Do not cut spring-wire guide against needle bevel to minimize the risk of possible severing or damaging of spring-wire guide.**
- Hold spring-wire guide in place and remove introducer needle and Arrow® Raulerson Syringe (or catheter). **Precaution: Maintain firm grip on spring-wire guide at all times.** Use centimeter markings on spring-wire guide to adjust indwelling length according to desired depth of indwelling catheter placement.
- Enlarge cutaneous puncture site with cutting edge of scalpel, where provided, positioned away from the spring-wire guide. **Precaution: Once cutaneous puncture site is enlarged, retract scalpel in the protected position (refer to Fig. 10) to minimize the risk of cutting the spring-wire guide.** Use tissue dilator to enlarge site as required. **Warning: Do not leave tissue dilator in place as an indwelling catheter to minimize the risk of possible vessel wall perforation.**

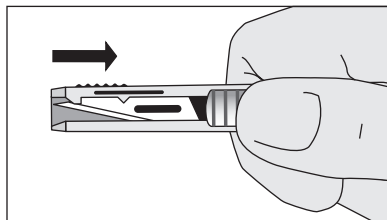

Fig. 10

- Thread tip of multiple-lumen catheter over spring-wire guide. Sufficient spring-wire guide length must remain exposed at hub end of catheter to maintain a firm grip on spring-wire guide. Grasping near skin, advance catheter into vein with slight twisting motion. **Precaution: If provided, catheter clamp and fastener must not be attached to catheter until spring-wire guide is removed.**

- Using centimeter marks on catheter as positioning reference points, advance catheter to final indwelling position. All centimeter marks are referenced from catheter tip. Marking symbology is as follows: (1) numerical: 5, 15, 25, etc.; (2) bands: each band denotes 10 cm intervals, with one band indicating 10 cm, two bands indicating 20 cm, etc.; (3) each dot denotes a 1 cm interval.
- Hold catheter at desired depth and remove spring-wire guide. The Arrow® catheter included in this product has been designed to freely pass over the spring-wire guide. If resistance is encountered when attempting to remove spring-wire guide after catheter placement, the spring-wire guide may be kinked about the tip of the catheter within the vessel (refer to Fig. 11).

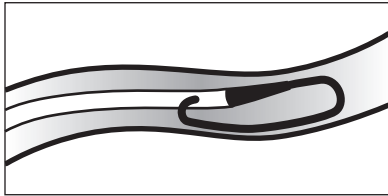

Fig. 11

In this circumstance, pulling back on the spring-wire guide may result in undue force being applied resulting in spring-wire guide breakage. If resistance is encountered, withdraw catheter relative to spring-wire guide about 2-3 cm and attempt to remove spring-wire guide. If resistance is again encountered remove spring-wire guide and catheter simultaneously. **Warning: Although the incidence of spring-wire guide failure is extremely low, practitioner should be aware of the potential for breakage if undue force is applied to the spring-wire guide.**

- Verify that entire spring-wire guide is intact upon removal.
- Check lumen placement by attaching a syringe to each extension line and aspirate until free flow of venous blood is observed. Connect all extension lines to appropriate Luer-Lock line(s) as required. Unused port(s) may be “locked” through injection cap(s) using standard hospital protocol. Slide clamps are provided on extension lines to occlude flow through each lumen during line and injection cap changes. **Precaution: To minimize the risk of damage to extension lines from excessive pressure, each clamp must be opened prior to infusing through that lumen.**
- Secure and dress catheter temporarily.
- Verify catheter tip position by visual imaging immediately after placement. **Precaution: Visual exam must show the catheter located in the right side of the mediastinum in the SVC with the distal end of catheter parallel to the vena cava wall and its distal tip positioned at a level above either the azygos vein or the carina of the trachea, whichever is better visualized.** If catheter tip is malpositioned, reposition and re-verify.
- Secure catheter to patient using staple anchoring device, sutures, or StatLock® anchoring device (where provided). Use triangular juncture hub with side wings as primary suture site. In kits where provided, the catheter clamp and fastener should

be utilized as a secondary suture site as necessary. **Precaution: Do not staple/suture directly to outside diameter of catheter to minimize the risk of cutting or damaging the catheter or impeding catheter flow.** Dress insertion site according to hospital protocol.

#### Staple Anchoring Device (where provided)

##### Instructions for Use:

- Position thumb and index finger of dominant hand on indented surface of staple anchoring device.
- Pass staple point through eye of catheter suture hub (refer to Fig. 12).

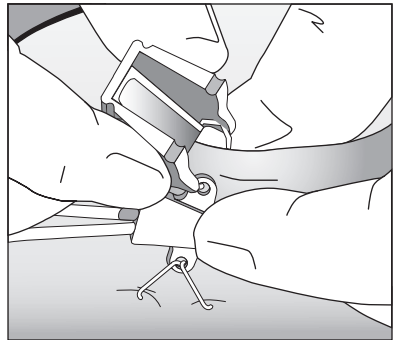

Fig. 12

- Tent skin and position with hub eye between staple opening. **Precaution: Do not place staple over catheter body or extension lines except at indicated anchoring location to minimize the risk of damage to catheter.**
- Firmly squeeze anchoring device together to close staple and secure catheter to skin (refer to Fig. 13).

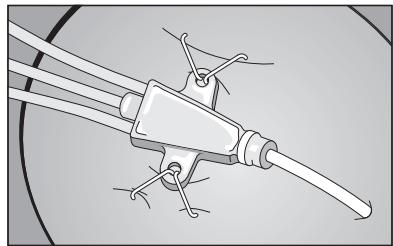

Fig. 13

- Repeat procedure through other suture eyes, if applicable. Discard anchoring device upon completion.

#### Catheter Clamp and Fastener (where provided)

##### Instructions for Use:

- After spring-wire guide has been removed and the necessary lines have been connected or locked, spread wings of rubber clamp and position on catheter making sure that catheter is not moist, as required, to maintain proper tip location (refer to Fig. 14).

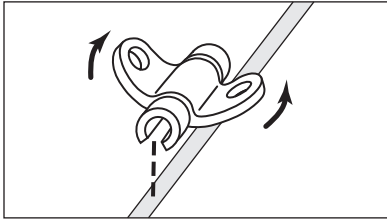

Fig. 14

- Snap rigid fastener onto catheter clamp (refer to Fig. 15).

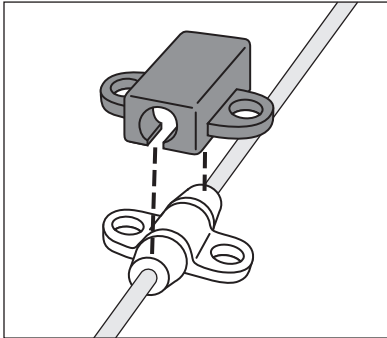

Fig. 15

- Secure catheter to patient by stapling or suturing catheter clamp and fastener together to skin, using side wings to minimize the risk of catheter migration (refer to Fig. 16).

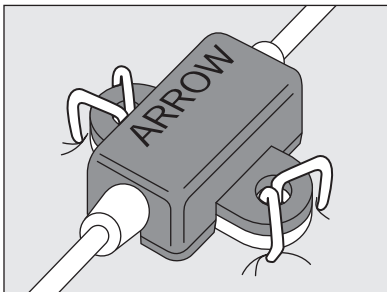

Fig. 16

20. Verify catheter tip position by visual imaging immediately after placement. **Precaution: Visual exam must show catheter located in the right side of the mediastinum in the SVC with the distal end of catheter parallel to the vena cava wall and its distal tip positioned at a level above either the azygos vein or the carina of the trachea, whichever is better visualized.** If catheter tip is malpositioned, reposition, resecure, and re-verify.

21. Dress puncture site per hospital protocol. **Precaution: Maintain the insertion site with regular meticulous redressing using aseptic technique.**
22. Record on the patient's chart all the information required per hospital protocol, being sure to include the indwelling catheter length as to centimeter markings on catheter where it enters the skin. Frequent visual reassessment should be made to ensure that the catheter has not moved.

### Maintain Catheter Patency:<sup>25</sup>

1. Solution and frequency of flushing a vascular access catheter should be established in hospital/agency policy.
2. Catheter patency is established and maintained by flushing intermittently via syringe with heparinized saline or preservative-free 0.9% sodium chloride (USP); continuous drip or a positive pressure device. The amount of heparin, if any, depends on physician preference, hospital/agency protocol, and patient condition. **Precaution: Heparin-induced thrombocytopenia (HIT) has been reported with the use of heparin flush solutions.**
3. The volume of flush solution should be equal to twice the priming volume of the lumen(s) of the catheter, PLUS the volume of any "add-on" device.
4. When using a CVC for intermittent infusion therapy, proper flushing (heparinization) using a positive-pressure flushing technique will prevent occlusion.
  - Saline • Administer drug • Saline • Heparin (if used)

*The SASH method of flushing will help eliminate occlusions due to incompatible solutions.*

### Catheter Exchange Procedure:

1. Use sterile technique.
2. **Precaution: Prior to attempting a catheter exchange procedure, remove catheter clamp and fastener (where provided).**
3. Proceed per hospital protocol. Cutting the catheter is not recommended due to the potential for catheter embolism.

### Catheter Removal Procedure:

1. Place patient in a supine position.
2. Remove dressing. **Precaution: To minimize the risk of cutting catheter, do not use scissors to remove dressing.**
3. Using staple remover, remove staple(s) from catheter clamp, where applicable, and primary suture site. Remove catheter slowly, pulling it parallel to the skin. **Precaution: To minimize the risk of catheter breakage, do not exert excessive force while removing the catheter.** As catheter exits the site, apply pressure with a dressing impermeable to air, e.g. Vaseline<sup>®</sup> gauze. **Warning: Since the residual catheter track remains an air entry point until completely sealed, the occlusive dressing should remain in place for at least 24-72 hours dependent upon the amount of time the catheter was indwelling.**<sup>20,21</sup>
4. Upon removal of catheter, inspect it to make sure that entire length has been withdrawn.
5. Document removal procedure.

### References:

1. Allgeyer DO, Herr GP, Szeftel A, Shapiro SM, et al. Evaluation of a Sharps Safety-Enhanced Device for Skin Fixation of Central Venous Catheters. *Anesthesiology*. 93(3A);2000:A-593.

2. Andrews RT, Bova DA, Venbrux AC. How much guidewire is too much? Direct measurement of the distance from subclavian and internal jugular vein access sites to the superior vena caval-atrial junction during central venous catheter placement. *Crit Care Med.* Jan. 2000;28:138-142.
3. Bach A, Bohrer H, Bottiger B, Motsch J, Martin E. Reduction of bacterial colonization of triple-lumen catheters with antiseptic bonding in septic patients. *Anesthesiology.* 1994;81:A261.
4. Bach A, Schmidt H, Bottiger B, Schreiber B, Bohrer H, Motsch J, Martin E, Sonntag H. Retention of Antibacterial Activity and Bacterial Colonization of Antiseptic-Bonded Central Venous Catheters. *J Antimicrob Chemother.* 1996;37:315-322.
5. Bar-Joseph G, Galvis AG. Perforation of the heart by central venous catheters in infants: guidelines to diagnosis and management. *J Pediatr Surg.* 1983;18:284-287.
6. Blitt CD, ed. *Monitoring in Anesthesia and Critical Care Medicine.* Central venous pressure monitoring. New York, NY: Churchill Livingstone; 1985:121-165.
7. Brandt RL, Foley WJ, Fink GH, Regan WJ. Mechanism of perforation of the heart with production of hydropericardium by a venous catheter and its prevention. *Am J Surg.* 1970;119:311-316.
8. Carbone K, Gimenez LF, Rogers WH, Watson AJ. Hemothorax due to vena caval erosion by a subclavian dual-lumen dialysis catheter. *South Med J.* 1987;80:795-796.
9. Center for Disease Control and Prevention. Guidelines for the prevention of intravascular catheter-related infections. *MMWR.* August 9, 2002/51(RR10);1-26.
10. Civetta J, Hudson-Civetta J, Ball S. Decreasing catheter-related infection and hospital costs by continuous quality improvement. *Crit Care Med.* 1996;24:1660-5.
11. Cobb DK, High KP, Sawyer RF, Sable CS, Adams RB, Lindley DA, Pruett TL, Schwenzler KJ, Farr BM. A controlled Trial of Scheduled Replacement of Central Venous and Pulmonary-Artery Catheters. *N Engl J Med.* 1992;327:1062-8.
12. Collier PE, Ryan JJ, Diamond DL. Cardiac tamponade from central venous catheters – report of a case and review of the English literature. *Angiology.* September 1984;35:595-600.
13. Currelaru J, Linder LE, Gustavsson B. Displacement of catheters inserted through internal jugular veins with neck flexion and extension. *Intens Care Med.* 1980;6:179-183.
14. Eissa NT, Kvetan V. Guide wire as a cause of complete heart block in patients with preexisting left bundle branch block. *Anesthesiology.* 1990;73:772-774.
15. Greene ES, Berry AJ, Jagger J, Hanley E, et al. Multicenter Study of Contaminated Percutaneous Injuries in Anesthesia Personnel. *Anesthesiology.* 1998;89:1362-72.
16. Hightower D, March J, Ausband S, Brown LH. Comparison of Staples vs Suturing for Securing Central Venous Catheters. *Acad. Emerg. Med.* 1996;3:1103-5.
17. Iberti TJ, Katz LB, Reiner MA, Brownie T, Kwun KB. Hydrothorax as a late complication of central venous indwelling catheters. *Surgery.* November 1983;842-846.
18. Infusion Nurses Society. Infusion Standards of Practice. *J Infusion Nurs.* 2006;29(1S).
19. Jobs DR, Schwartz AJ, Greenhow DE, Stephenson LW, Ellison N. Safer jugular vein cannulation: recognition of arterial punctures and preferential use of the external jugular route. *Anesthesiology.* 1983;59:353-355.
20. Kanegaye JT, Vance CW, Chan L, Schonfeld N. Comparison of skin stapling devices and standard sutures for pediatric scalp lacerations: A randomized study of cost and time benefits. *The Journal of Pediatrics.* 1996;130:808-13.
21. Kashuk JL, Penn I. Air embolism after central venous catheterization. *Surg Gynecol Obstet.* September 1984;159:249-252.
22. Kozeny GA, Bansal VK, Vertuno LL, Hano JE. Contralateral hemothorax secondary to chronic subclavian dialysis catheter. *Am J Nephrol.* 1984;4:312-314.
23. Macklin D. What's physics got to do with it? *JVAD.* 1999; 4(2):7-11.
24. Maki DG, Ringer M. Evaluation of dressing regimes for prevention of infection with peripheral intravenous catheters. *JAMA.* 1987;258:2396-2403.
25. Maschke SP, Rogove HJ. Cardiac tamponade associated with a multilumen central venous catheter. *Crit Care Med.* 1984;12:611-612.
26. Mermel LA, McCormick RD, Springman SR, Maki DG. The pathogenesis and epidemiology of catheter-related infection with pulmonary artery Swan-Ganz catheters: A prospective study utilizing molecular subtyping. *AJM.* 1991;91(suppl 3B):3B-197S-3B-205S.
27. NNIS. National Nosocomial Infections Surveillance System (NNIS) system report, data summary from January 1992 through June 2004, issued October 2004. *AJIC.* 2004;32: 407-485.
28. Norman PS, Peebles RS. In vivo Diagnostic Allergy Testing Methods. In: Rose NR, Conway de Macario E, Fields JD, Lane HC, Nakamura RM. *Manual of Clin. Lab. Immunol.* Washington DC: AMS Press; 1997, 5th Edition.
29. Occupational Exposure to Bloodborne Pathogens; Needlestick and Other Sharps Injuries. 66 Federal Register 5317 (2001) (Codified at 29 CFR–1910.1030).
30. Paskin DL, Hoffman WS, Tuddenham WJ. A new complication of subclavian vein catheterization. *Ann Surg.* March 1974;179:266-268.
31. Peters JL, ed. *A Manual of Central Venous Catheterization and Parenteral Nutrition.* Boston, MA: John Wright PSG; 1983:58-61, 155-157.
32. Phifer TJ, Bridges M, Conrad SA. The residual central venous catheter track – an occult source of lethal air embolism: case report. *J Trauma.* 1991;31:1558-1560.
33. Sheep RE, Guiney WB Jr. Fatal cardiac tamponade. *JAMA.* 1982;248:1632-1635.
34. Sherertz RJ, Heard SO, Raad II. Diagnosis of triple-lumen catheter infection: comparison of roll plate, sonication, and flushing methodologies. *J Clin Microbiol.* 1997;35:641-646.
35. Sherertz RJ. Pathogenesis of vascular catheter-related infections. In: Seifert H, Jansen B, Farr BM, eds. *Catheter-Related Infections.* New York, NY: Marcel Dekker, Inc; 1997:1-29.
36. Sigurdsson J, Riba P, Sigurdsson S. The wandering central venous catheter. *Intensive Care Med.* 1985;11:263-264.
37. Thielen JB, Nyquist J. Subclavian catheter removal. *J Intravenous Nurs.* March/April 1991;14:114-118.
38. Tocino IM, Watanabe A. Impending catheter perforation of superior vena cava: radiographic recognition. *Am J Roentgenology.* March 1986;146:487-490.



39. Tomkins DP, Van Der Walt JH. Needleless and Sharp-Free Anaesthesia. *Anaesthesia and Intensive Care*. 1996;24:164-7.
40. Tsuneto S, Watanabe S, Koyama K, Nakayama K, Saito H, Saito K. Anaphylactic shock induced by chlorhexidine mixed in the vial of lidocaine. *J Japan Society Clin Anesthesia*. 1987;7:272-277.
41. Turkeltaub PC, Rastogi SC, Baer H, Anderson MC, Norman PS. Standardized quantitative skin-test assay of allergen potency and stability: Studies on the allergen dose-response curve and effect of wheal, erythema, and patient selection on assay results. *J Allergy Clin Immunol*. 1982;70:343-352.
42. Vaziri ND, Maksy M, Lewis M, Martin D, Edwards K. Massive mediastinal hematoma caused by a double-lumen subclavian catheter. *Artif Organs*. 1984;8:223-226.
43. Wanscher M, Frifelt JJ, Smith-Sivertsen C, et al. Thrombosis caused by polyurethane double-lumen subclavian superior vena cava catheter and hemodialysis. *Crit Care Med*. 1988;16:624-628
- Arrow International, Inc. recommends that the user be acquainted with the reference literature.
- \* If you have any questions or would like additional reference information, please contact Arrow International, Inc.
- † A registered trademark of Unilever Supply Chain, Inc.





**STERILE EO**

K-12702-106A (9/07)

**ARROW<sup>®</sup>**

INTERNATIONAL  
2400 Bernville Road  
Reading, PA 19605 USA  
1-800-523-8446  
1-610-378-0131  
8 a.m. - 8 p.m. EST